

FAMILY NAME 产品系列	UV-C lamp type UV-C 光源型号	Ballast type 整流器型号	Useful lamp lifetime 光源使用寿命	kg
	(12 NC)	(12 NC)		
SM345C	TUV PL-S 9W/4	HF-M RED 109 SH TL/PL-S 220-240V	9000 hrs	7
	(927901904007)	(913700422880)		

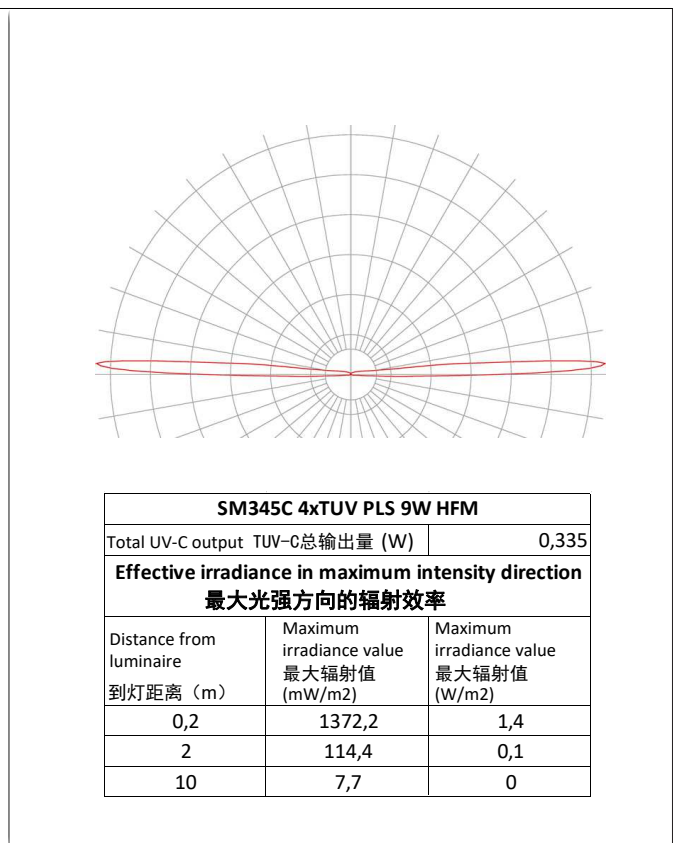
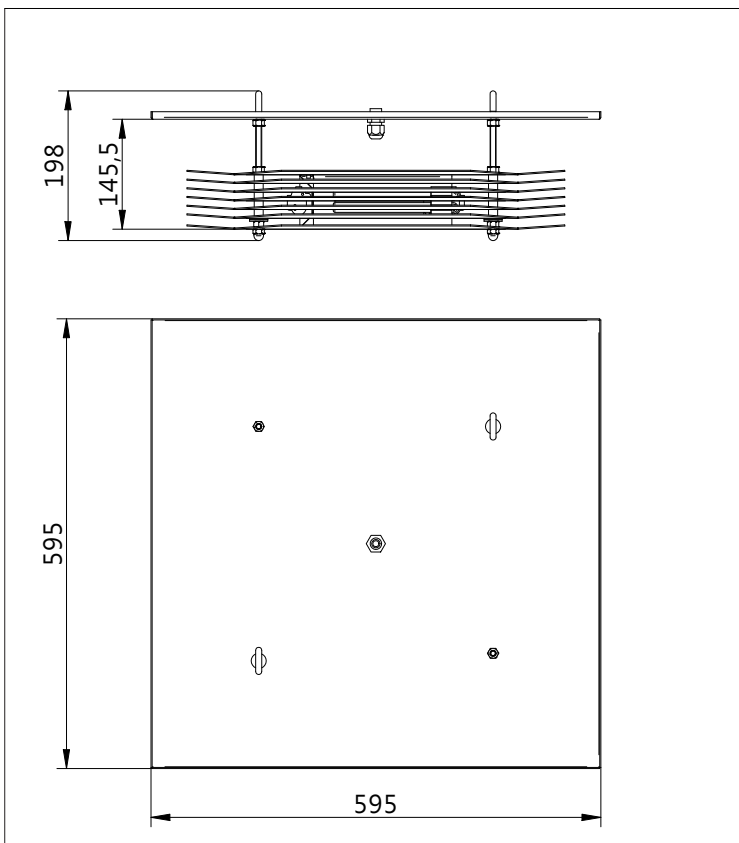

Signify (China) Investment Co., Ltd.
 Building No. 9, Lane 888 Tianlin Road,
 Minhang District, Shanghai, China
 Postalcode: 200233
 昕诺飞 (中国) 投资有限公司
 中国上海市闵行区田林路888弄9号楼
 邮编: 200233

内容如有变更, 恕不另行通知
 Data subject to change without notice

Scan QR code or follow the link to get to training materials
www.philips.com/uvctraining
 扫描二维码或查询链接, 获得相关培训资料



Philips and the Philips shield emblem are registered trademarks of Koninklijke Philips N.V.

Installation requirement 安装步骤

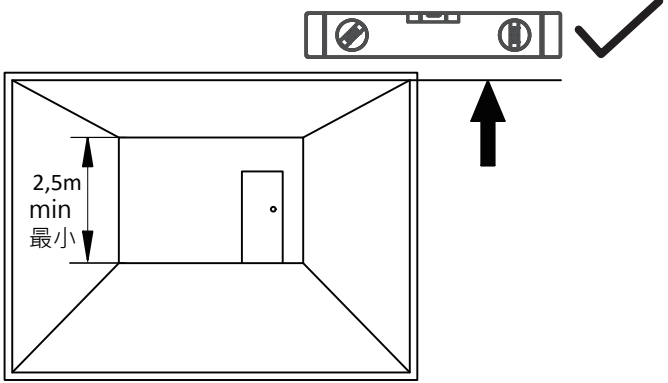

2,5m
min
最小

1

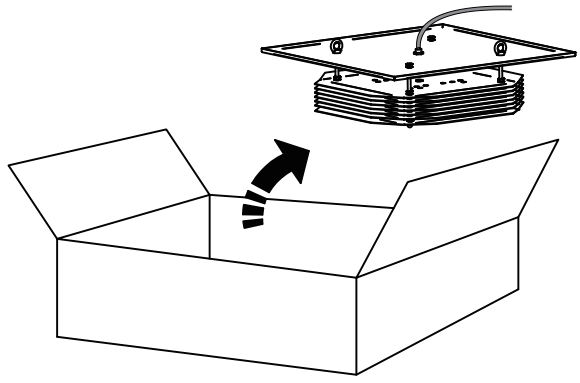

2

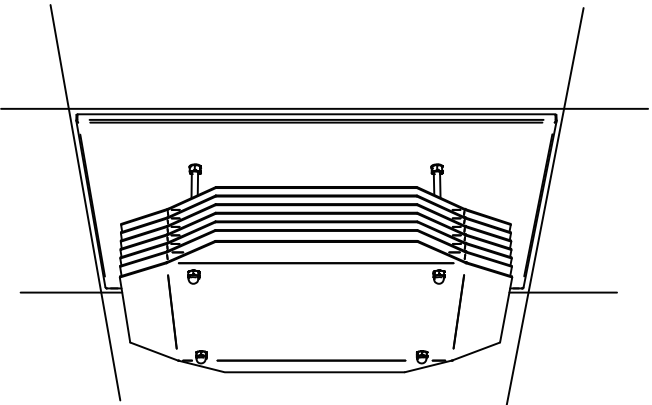

3

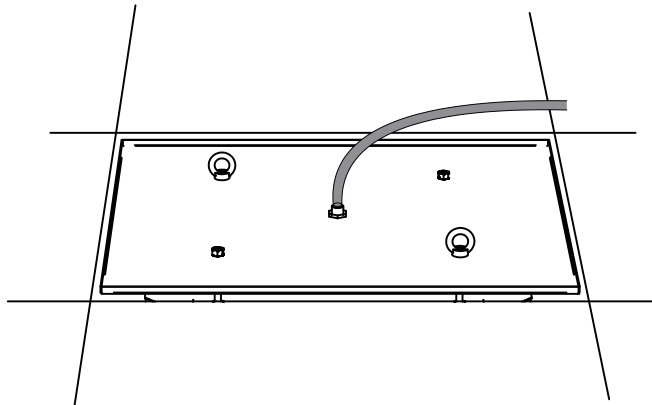

4

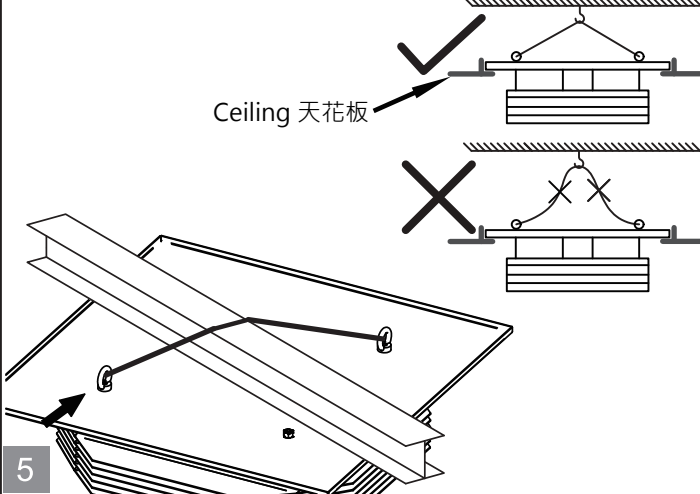

Ceiling 天花板

5

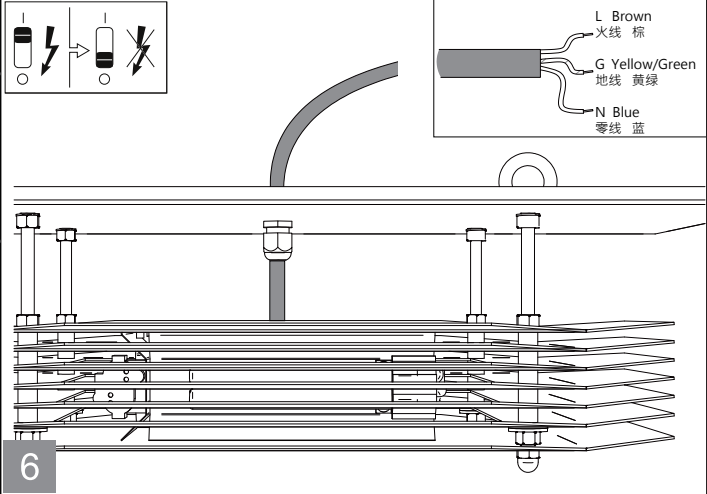

6

- L Brown 火线 棕
- G Yellow/Green 地线 黄绿
- N Blue 零线 蓝

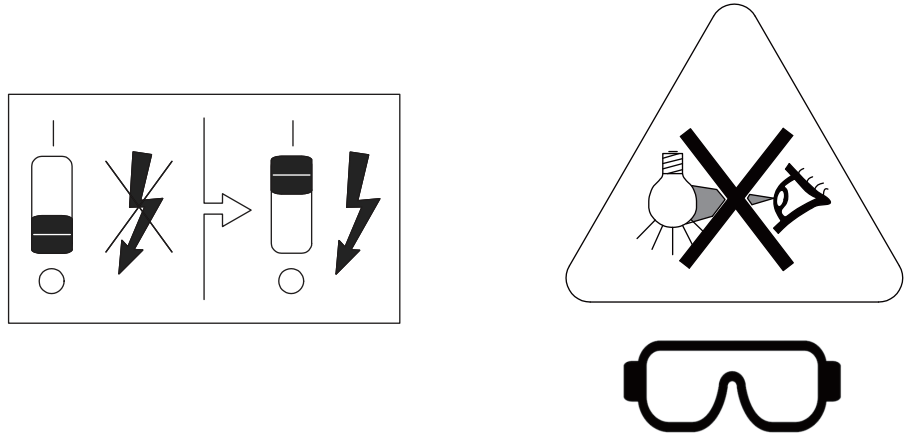

7

Maintenance or UV-C lamp replacement 维护或UV-C光源替换

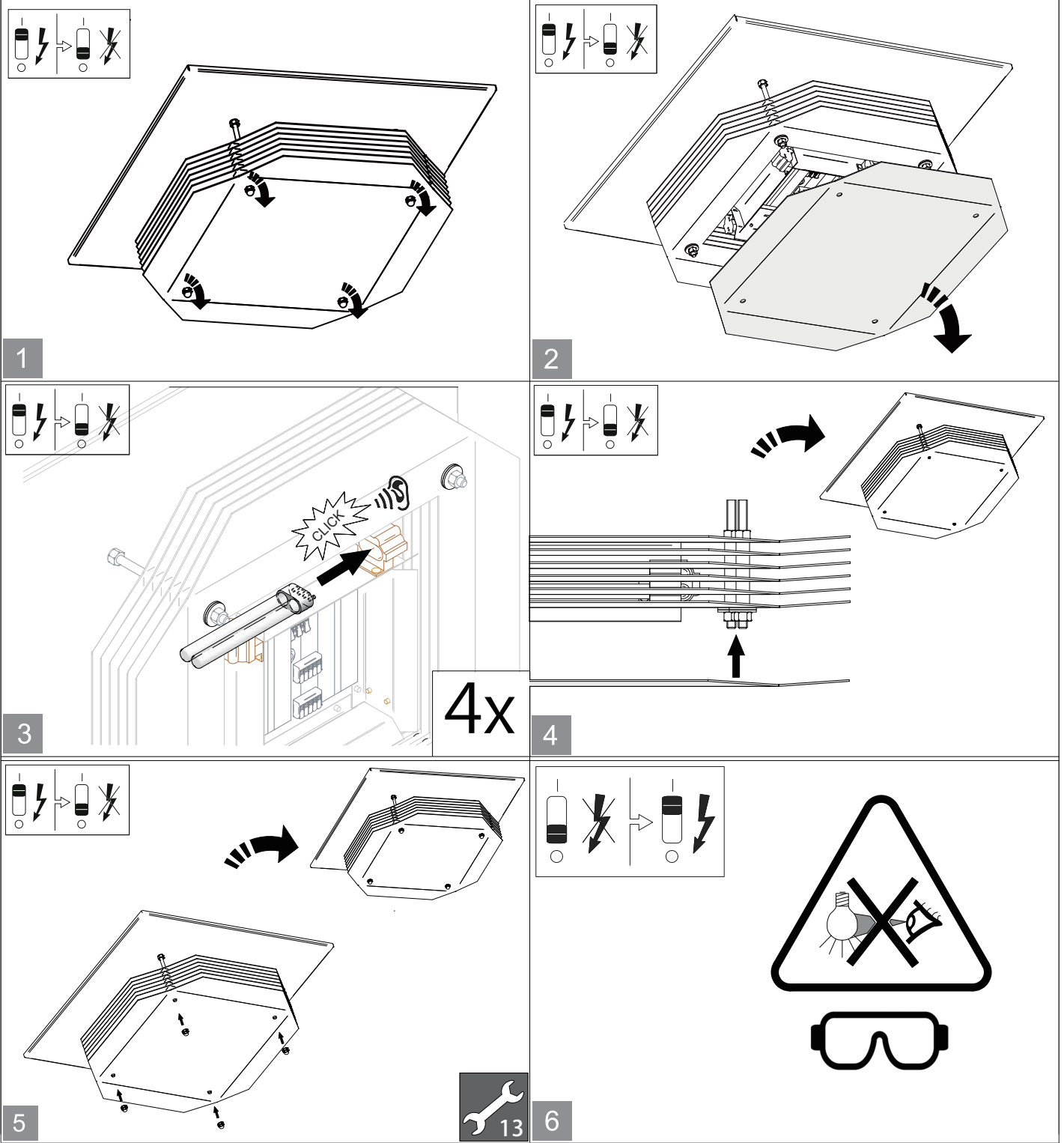

Inrush current

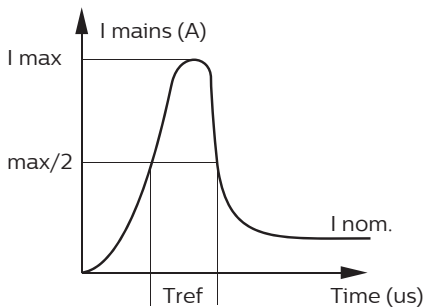

Electrical characteristics 电气特性	
I_{max} (A)	13
T_{ref} (μs)	111
MCB Max. luminaires 灯最多连接数	
B-10 A	43
B-16 A	70
C-10 A	72
C-16 A	115

USER MANUAL

Content

1. UV-C basic information
2. Applicable safeguards and installation requirements for the wall mount UV-C device
3. Maintenance and safe use
4. Warnings concerning reasonably foreseeable improper usage, malfunctions, and hazardous failure modes.

1 UV-C basic information

What is UV-C?

Ultraviolet (UV) light is invisible to human eyes. It can be subdivided into three categories:

- UV-C from 200 to 280 nm - For disinfection purposes and germicidal application.
- UV-B from 280 to 315 nm - For medical use (i.e. phototherapy to treat skin conditions, including psoriasis).
- UV-A from 315 to 400 nm - For use with curing, tanning and insect traps.

How does UV-C work?

- UV-C radiation can break the DNA and RNA of bacteria, viruses and spores, meaning that they leave them harmless. There are no known micro-organisms resistant to UV-C¹.
- UV-C technology has been used safely and effectively in hospitals and governmental buildings for more than 40 years².
- Most UV-C solutions utilize conventional lighting, with LED now improving in efficiency.
- The peak output of our germicidal lamps (253.7nm) is close (80-85%) to the maximum effectiveness of UV-C (265nm).
- Smaller UV-C wavelengths (222nm) are being explored as less harmful alternatives.

2 Installation requirements and safeguards for this product

The device described in this guide is designed to operate and provide UV-C irradiation in the open air of indoor rooms for disinfection. The disinfection happens in a germicidal zone over the height where people are occupying the room. Staying in the room where these luminaires are installed and turned on is allowed if the below instructions are followed while being present in the subject indoor room. To achieve this safe condition, the following precautions must be taken and followed and kept during use:

2.1 Installation, electrical connection, and verification of installed products,

- 2.1.1 Installation of the products referenced herein should only happen after a design of the UV-C irradiation in the application itself, which defines exact positions for installation. (referenced commonly as lighting design).
- 2.1.2 The product installation must follow the pictorial instructions provided in this document, with the below precautions to be followed:
 - a. Check the product after unpacking for damage. Do not install physically damaged product.
 - b. Only install into ceilings that meets the following criteria:
 - i. Suitable to hold luminaire weight
 - ii. The ceiling is horizontal and suitable for the size of the fixture
 - iii. The product must be installed in a safe height as described in the pictorial instructions
 - iv. Attach safety anchorage strap to the luminaire to both top connection points (behind the ceiling after installation), as additional safety measure (safety strap not included)
- 2.1.3 The product must be installed on a power circuit which meets the following criteria:
 - A. Can be turned on/off separately from any general lighting used in the building
 - B. It meets the national electric code of the actual country of use and installation
 - C. It is separated from any lighting system by its own circuit breaker
 - D. The input power switch must be lockable for safe shutdown during maintenance

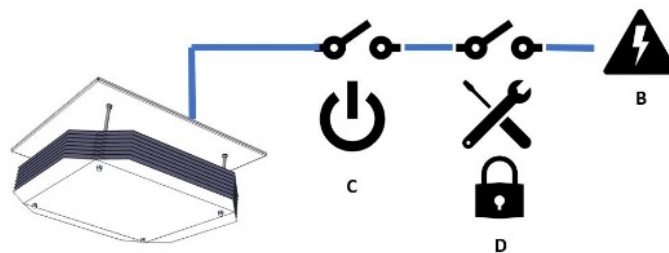

¹ Fluence (UV Dose) Required to Achieve Incremental Log Inactivation of Bacteria, Protozoa, Viruses and Algae Revised, updated and expanded by Adel Haji Malayeri, Madjid Mohseni, Bill Cairns and James R. Bolton. With earlier contributions by Gabriel Chevrefils (2006) and Eric Caron (2006) With peer review by Benoit Barbeau, Harold Wright (1999) and Karl G. Linden

² EPA Report, "Building Retrofits for Increased Protection Against Airborne Chemical and Biological Releases" Pg. 56

2.2 Visible marking of freely accessible height

Heights defined in this section are as below, defined by the distance to the floor.

- Ceiling height – Height of the ceiling measured from the floor, and has a minimum value of 2.5 m.
- Accessible height – Height, which defines the level to stay below during the operation of the UV-C unit. This height has a minimum value of 2.3 m.

During normal use of this product, it is strictly forbidden to climb, reach and/or enter by any means into the zone which is above the Accessible height. Above the accessible height, UV-C irradiance is high enough to cause injury and/or pose risk to human health.

The below marking needs to be placed into the room where the product is installed to distinguish and mark the accessible height. The markings must not blend into the surroundings. The height of installation of these marks is 1,75m from the floor for all locations where markings must be installed. It is not allowed to remove or cover the marks after installation by any means (examples of not allowed covering: overpainting, covering by furniture, temporary removal). If the actual position of installation requires, use additional fixation to prevent the markings from being removed from their position after installation (example: fixing with additional pins to avoid peeling off)

The marks must be placed in the following locations in the rooms where the product is installed.

- Any entry point to the room where the product is installed (example: outside of the door(s) of entry)
- Under the product itself or on the closest wall where free access in the room is available. If multiple fixtures installed in the same room, at least 1 mark per unit must be placed on the wall.

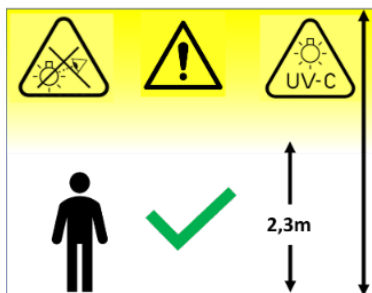

Survey the room with a sensitive UV-C meter at 1,75m height for UV-C levels. Ensure that the used UV-C meter is capable to measure within the range of 0,2uW/cm² irradiance.

Commissioning (Verification of the mounted products)

Installation of the products referenced herein should only happen after a design of the UV-C irradiation in the application itself (referenced generally as lighting design). In any case the installation cannot be handed over to the final customer without final commissioning of the products in the actual installation.

Steps of verification of the installed products are as below:

- Install luminaire to the pre-designed positions according to this document following all instructions
- Stay on the ground level and make sure no one is staying above 2m.
- Use personal protective equipment that protect against UV-C irradiation and/or accidental exposure.
- Turn on power to the luminaires.
- Survey the room with a sensitive UV-C meter at 1,75m height for UV-C levels. Ensure that the used UV-C meter is capable to measure within the range of 0,2uW/cm² irradiance.
- UV-C levels are acceptable if they are at 0,2uW/cm² for an 8 hour exposure time, or an equivalent dose as per ISO 15858.
- If the intensity level is not according to the usage of the room (Exposure time and/or irradiance) the position and number of units should be reconsidered and adjusted to reach the required level of irradiance in the actual installation.

3 Maintenance:

The unit is designed for minimum maintenance need and time. Possible maintenance for the unit by a qualified person is limited to changing lamps in the unit.

Occasional UV-C measurements must be made to ensure that the UV-C levels in the treated areas remain within the allowable exposure limits. A regular cycle of cleaning the lamp and interior reflector must be established based on visual inspection and experience. The frequency of cleaning will vary with the conditions surrounding each installation. It is recommended that the lamp and reflector be cleaned at least every 6 months.

Lamp exchange needs can be identified by the lamps operating hours, or by doing periodic irradiance measurements at pre-defined positions of the actual installation in the final environment.

Lamp exchange and/or cleaning procedure must be executed in this order:

1. Identify the unit that needs cleaning or maintenance.
2. Use personal protective equipment that protect against UV-C irradiation and/or accidental exposure.
3. Make sure that power is turned off at the switch that is switching the UV-C devices centrally.
4. Lock out and tag out the lockable switch which in off state. This ensures safety during maintenance against accidental turn on.
5. Remove the 4 capped nuts from the bottom and remove the white bottom plate

6. Take out the 4 lamps by pulling it forward from the holder.
7. Clean the lamps with a soft, lint-free cloth.
8. Clean the reflectors with a soft, lint-free cloth. For reflectors, the cloth may be moistened with pure alcohol.
9. Place the lamp back into the lamp holders. If replacing lamp, place new lamp into position. Lamps contain mercury. Replaced old lamps should be disposed properly!
10. Re position the white plate and place the capped nuts back into position. Tighten the capped nuts.
11. Leave the area of the UV-C beam and stay in the freely accessible zone as defined by the visible marking safeguard.
12. Remove the lockout tagout from the switch at the central switch location
13. Turn on power
14. Repeat the commissioning process to make sure that after lamp replacement, the irradiance levels are still acceptable

In case of lamp breakage follow below instruction:

Before Cleanup:

- Have people and pets leave the room and avoid the breakage area on the way out.
- Open a window or door to the outdoors and leave the room for 5-10 minutes.
- Shut off the central forced-air heating/air conditioning (HVAC) system if you have one.
- Collect materials you will need to clean up the broken bulb:
- Stiff paper or cardboard
- Sticky tape (e.g., duct tape)
- Damp paper towels or disposable wet wipes (for hard surfaces)
- Glass jar with a metal lid (such as a canning jar) or a sealable plastic bag(s)

Cleanup Steps for Hard Surfaces

1. Carefully scoop up glass fragments and powder using stiff paper or cardboard and place debris and paper/cardboard in a glass jar with a metal lid. If a glass jar is not available, use a sealable plastic bag. (NOTE: Since a plastic bag will not prevent the mercury vapor from escaping, remove the plastic bag(s) from the home after cleanup.)
2. Use sticky tape, such as duct tape, to pick up any remaining small glass fragments and powder. Place the used tape in the glass jar or plastic bag.
3. Wipe the area clean with damp paper towels or disposable wet wipes. Place the towels in the glass jar or plastic bag.
4. Vacuuming of hard surfaces during cleanup is not recommended unless broken glass remains after all other cleanup steps have been taken. [NOTE: It is possible that vacuuming could spread mercury-containing powder or mercury vapor, although available information on this problem is limited.] If vacuuming is needed to ensure removal of all broken glass, keep the following tips in mind:
 - a. Keep a window or door to the outdoors open.
 - b. Vacuum the area where the bulb was broken using the vacuum hose, if available; and
 - c. Remove the vacuum bag (or empty and wipe the canister) and seal the bag/vacuum debris, and any materials used to clean the vacuum, in a plastic bag.
5. Promptly place all bulb debris and cleanup materials, including vacuum cleaner bags, outdoors in a trash container or protected area until materials can be disposed of. Avoid leaving any bulb fragments or cleanup materials indoors.
6. Next, check with your local government about disposal requirements in your area, because some localities require fluorescent bulbs (broken or unbroken) be taken to a local recycling center. If there is no such requirement in your area, you can dispose of the materials with your household trash.
7. Wash your hands with soap and water after disposing of the jars or plastic bags containing bulb debris and cleanup materials.
8. Continue to air out the room where the bulb was broken and leave the HVAC system shut off, as practical, for several hours.

Cleanup Steps for Carpeting or Rugs

1. Carefully scoop up glass fragments and powder using stiff paper or cardboard and place debris and paper/cardboard in a glass jar with a metal lid. If a glass jar is not available, use a sealable plastic bag. (NOTE: Since a plastic bag will not prevent the mercury vapor from escaping, remove the plastic bag(s) from the home after cleanup.)
2. Use sticky tape, such as duct tape, to pick up any remaining small glass fragments and powder. Place the used tape in the glass jar or plastic bag.
3. Vacuuming of carpeting or rugs during cleanup is not recommended unless broken glass remains after all other cleanup steps have been taken. [NOTE: It is possible that vacuuming could spread mercury-containing powder or mercury vapor, although available information on this problem is limited.] If vacuuming is needed to ensure removal of all broken glass, keep the following tips in mind:
 - a. Keep a window or door to the outdoors open
 - b. Vacuum the area where the bulb was broken using the vacuum hose, if available, and
 - c. Remove the vacuum bag (or empty and wipe the canister) and seal the bag/vacuum debris, and any materials used to clean the vacuum, in a plastic bag.

4. Promptly place all bulb debris and cleanup materials, including vacuum cleaner bags, outdoors in a trash container or protected area until materials can be disposed of. Avoid leaving any bulb fragments or cleanup materials indoors.
5. Next, check with your local government about disposal requirements in your area, because some localities require fluorescent bulbs (broken or unbroken) be taken to a local recycling center. If there is no such requirement in your area, you can dispose of the materials with your household trash.
6. Wash your hands with soap and water after disposing of the jars or plastic bags containing bulb debris and cleanup materials.
7. Continue to air out the room where the bulb was broken and leave the HVAC system shut off, as practical, for several hours.

Future Cleaning of Carpeting or Rugs:

1. Air Out the Room During and After Vacuuming
2. The next several times you vacuum the rug or carpet, shut off the HVAC system if you have one, close the doors to other rooms, and open a window or door to the outside before vacuuming. Change the vacuum bag after each use in this area.
3. After vacuuming is completed, keep the HVAC system shut off and the window or door to the outside open, as practical, for several hours.

4 Reasonably foreseeable improper usage, malfunctions, and hazardous failure modes.

Issue / Failure mode	Potential effect (s of failure)	Potential cause(s) / Mechanism(s) of failure	Prevention
Irradiance too low in the germicidal zone	dose too low leading to reduced disinfection rate which may cause airborne pathogens remaining inactivated	T ambient of application	Temperature monitoring, keep temperature within limits described in product specification
	dose too low leading to reduced disinfection rate which may cause airborne pathogens remaining inactivated	shadowed area of UV-C	Make sure treated area will not be shadowed by other objects
	dose too low leading to reduced disinfection rate which may cause airborne pathogens remaining inactivated	dust on UV-C source	Make sure lamp (UV-C source) is clean and free of dust
No dose at all - thus no disinfection function	Luminaire is not on	luminaire is not connected	Connect luminaire according to manual instruction
	driver not working	luminaire is not switched on	Switch on luminaire with all safety measure described in user manual
	Lamp not working	end of life or failure of driver	Replace driver by authorized provider
Exposure to higher dose than allowed for 8 hours stay	Unintended human exposure to UV-C, sunburn-like reaction to the skin and serious damage to the cornea	Too high reflections from walls	Do not allow changes to room layout after installation.
Exposure to higher dose than allowed for 8 hours stay	Unintended human exposure to UV-C, sunburn-like reaction to the skin and serious damage to the cornea	Too high reflections from walls	In case of rooms that have movable walls, commission for smallest room size layout.
Accidental exposure in the main beam	Unintended human exposure to UV-C, sunburn-like reaction to the skin and serious damage to the cornea	Visible marking safeguard is not followed	Check training materials and user manual. Reinforce use of visible marking safeguard
Accidental exposure in the main beam	Unintended human exposure to UV-C, sunburn-like reaction to the skin and serious damage to the cornea	Visible marking safeguard is not installed	
Lamp is broken during replacement	Hg from the lamp may contaminate surface and room	Accidental fall of lamp while relamping	Be careful and focused while relamping. Follow replacement instruction. In case of breakage follow instruction how to clean Hg contamination.
Goods and surroundings damage due to UV-C	Material degradation, painting fade away due to UV-C	Precious goods and non UV-C resistant materials around luminaire in germicidal zone are not secured while lamp operating	Make sure all precious goods / objects/ signs are removed or hidden/protected from direct UV-C application

(GB) Safety precautions



- This product is UV-C Risk Group 3 rated, according to IEC 62471.
- Warning: UV-C emitted from this product. Avoid eye and skin exposure to unshielded product. Follow installation instructions and user manual.
- Warning: Our UV-C Products are not meant to be used in applications or activities which may cause and/or lead to death, personal injury and/or damage to the environment.
- As UV-C is invisible to the eye, the UV-C device must be installed together with adequate safeguards to ensure that the UV-C device can be operated in a safe way.
- The UV-C device are only to be used as components in a system that consists of adequate safety safeguards such as, but not limited to, those indicated in the mounting instructions and/or user manuals.
- Warning: Do not use without reading the content in Instructional Safeguards (Mounting Instruction and User Manual), ensuring control solution Containment Safeguard in place and completing a Training Safeguard.
- Warning: Materials that are exposed to UV-C for a long time may become damaged and/or discolored.
- Lamps include Mercury. If a lamp breaks, ventilate the room for 30 minutes and remove the parts, preferably with gloves. Put them in a sealed plastic bag and take it to your local waste facilities for recycling. Do not use a vacuum cleaner. Please follow User Manual.
- The luminaire shall be installed by a qualified electrician and wired in accordance with the latest IEE electrical regulations or the national requirements.
- Driver insulation: Basic according to IEC 61347-1.
- During installation or when maintaining the luminaire please use static free gloves to avoid marks on the luminaire.
- To remove dirt and spots use the following:
 - Dust: only use microfiber cloths.
 - Fingerprints, etc.: use a cleaner for synthetic materials with antistatic properties.

操作指南

内容

1. UV-C 的基本信息
2. 应用 UV-C 吸顶安装型装置的安装要求和安全保障措施
3. 维护和安全使用要求
4. 关于可预测到的不正确操作、故障和危险失效模式的警告。

1 UV-C 的基本信息

UV-C 的定义？

(UV) 紫外光线是人眼不可见的，细分为三类：

- UV-C, 波长从200到280nm, 可用于消毒和杀菌。
- UV-B, 波长从280到315nm, 可用于医疗领域 (如对皮肤类疾病的光线疗法, 包括牛皮癣)。
- UV-A, 波长从315到400nm, 可用于食品加工业, 日光浴, 捕虫。

UV-C 是作用原理？

- UV-C辐射能灭活病毒、细菌和孢子的DNA和RNA, 使微生物无致病性, 这意味着能使它们无害化。目前还未发现有抗UV-C¹特性微生物的存在。
- 40多年来, UV-C技术在医院及市政建设中得到了安全有效的应用。²
- 大多数UV-C方案采用了传统光源, LED光线目前正在提供其工作效率。
- 我们提供的杀菌光源(253.7nm)在UV-C(265nm)波长处, 最大输出效率将近80-85%。
- 安全性更高的短波长UV-C(222nm)的应用, 目前还处于研究开发阶段。

2 本灯具的安装要求和安全保障措施

本操作指南所述灯具旨在提供UV-C辐射对室内房间的流通空气进行消毒。消毒作用的范围是在房间内正常走动人员高度外的上空区域。涉及室内场所的应用空间内, 如不符合本指南的所述, 关于此灯具的安装及运作要求时, 任何人员不得处于在此室内场所。为了达到此安全条件, 必须采取以下预防措施, 并在使用中严格遵循。

2.1 安装操作, 电气连接, 对灯具的安装验收

2.1.1 本指南所述灯具, 只能安装在指定有 UV-C 辐射要求的应用区域内, 并参考照明设计要求已明确了安装位置。

2.1.2 灯具安装必须遵循本指南所述的图示说明, 注意事项如下:

- a. 拆箱后检查灯具有无损坏。如发现存在任何损坏, 灯具不得安装。
- b. 只能应用于符合以下条件的吸顶式安装:
 - i. 能够承受灯具重量
 - ii. 吸顶安装面必须是水平的, 并适合于灯具的尺寸。
 - iii. 灯具必须安装在一个安全高度, 如图示说明
 - iv. 灯具安装后, 必须吸顶内部空间里加装安全链索具装置固定在灯具背面的两个吊环处, 作为附加的安全措施, 本灯具并不包含安全链索具装置。

2.1.3 灯具必须安装在符合以下标准的连接电气电路上:

- A. 符合通用的建筑照明要求, 并可独立开关控制
- B. 符合相应国家要求的使用及电气规范
- C. 具备独立的断路器, 不与其他照明系统共用。
- D. 在维护过程中, 输入电源开关装置必须具备有锁定断开的功能。

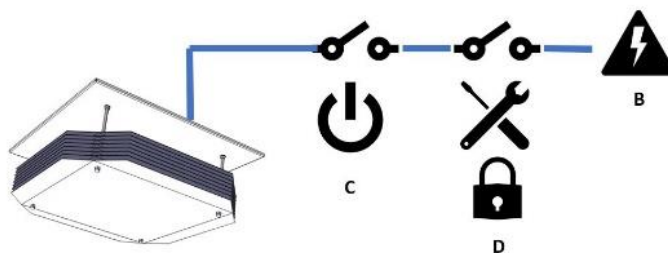

¹达到细菌、原生动物、病毒和藻类的增量对数失活所需的影响(UV 剂量), 是由 Adel Haji Malayeri, Madjid Mohseni, Bill Cairns and James R. Bolton 修订和更新, 并引用了 Gabriel Chevretils 和 Eric Caron 早期的文献, 由 Benoit Barbeau, Harold Wright 和 Karl G. Linden 进行了校订。

²环境保护局报告指出的, “用于加强防止空气中的生物释放的建筑改造。”

2.2 可进入区域高度限制的可见标识

本节中定义的高度为如下所述的，到指定地面的距离。

- 吸顶高度-从地面开始测量到的天花板高度，最小值为2.5米。
- 可进入区域高度-定义了UV-C灯具运行期间，人员可处于从地面开始测量的最小高度为2.3米的空间内。

在本灯具的正常使用期间，严禁以任何方式攀爬，触及或进入到“可进入区域高度”之外的区域。在“可进入区域高度”之外的区域，存在高强度的UV-C辐照度，会影响及危害到人类健康。

在安装灯具的房间内需须放置以下标识，用于警示安装有此灯具应用场合的“可进入区域高度”限制。标识粘贴处，应明显可见。在所有必须安装标识的位置，这些标识的安装高度为离地面1.75米。安装后，不得用任何方法移除或覆盖标识(例如：用油漆覆盖、有家具遮挡、临时移除)。在粘贴于指定的位置时，如有必要，可以使用额外的固定方式以防止标识从粘贴位置上脱落(例如：使用额外的钉子固定，以免脱落)

标识必须位于灯具安装房间的下列位置。

- 灯具安装所在房间的入口处(例如：入口的门外)
- 在灯具下方临近的墙面上。如果在同一房间安装有多个灯具，则必须在相应灯具临近的墙面上至少粘贴1个标识。

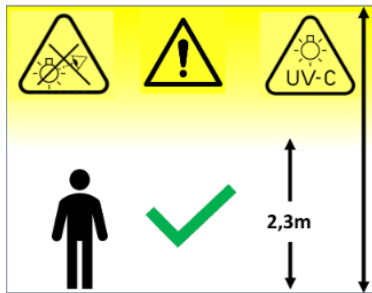

在离地面1.75米高距离处，使用UV-C探测器，测量室内环境UV-C的辐射强度。确保使用的UV-C探测器的精度能达到探测0.2uW/cm²d辐射强度的要求。

调试（灯具的安装验收）

首先必须在已经符合UV-C辐射照明设计要求的提前下再进行灯具安装。不能在实际安装中没有对灯具进行最终调试的任何情况下转交给客户使用。

灯具安装后的验收步骤如下：

- 根据本操作指南要求，将灯具安装在预先设计的位置
- 确保在场人员都待在地面上，没有人滞留在离地面2米以外的空间。
- 使用个人防护设备，以防止UV-C的辐射及意外暴露。
- 打开灯具电源。
- 在离地面1.75米高距离处，使用UV-C探测器，测量室内环境UV-C的辐射强度。确保使用的UV-C探测器的精度能达到探测0.2uW/cm²d辐射强度的要求。
- 人可接受暴露于UV-C辐射的等级要求为：辐射强度为0.2uW/cm²，暴露时间为8小时，或等效于ISO15858的判定等级。
- 当监测评估后，得到的所处环境内的UV-C等级不符合或尤其是高于上述UV-C等级要求（辐射强度为0.2uW/cm²，暴露时间为8小时）时，必须重新考虑并调整灯具的安装位置和数量，以在实际安装后符合上述规定的UV-C等级要求。

3 维护：

灯具设计有考虑到尽可能的降低维护及维护时所需的时间。须由有资格的电工对灯具进行必要的维护工作，仅限于更换灯具内的光源。

必须定期进行室内环境UV-C的辐射强度，以确保所处区域符合上述规定的UV-C等级要求。必须根据现场实际情况对灯具及反射器进行定期的清洗维护。清洗维护频率视现场实际情况而定。建议灯具及反光板至少每6个月清洗一次。灯具交换需要可以通过灯具的工作时间来确定，或者通过在最终环境中实际安装的预定义位置进行周期性辐照度测量来确定。

换灯和清洁程序必须按此顺序执行：

1. 确定需要清洗或维修的单位。
2. 使用个人防护设备，以防止紫外线-C辐射和/或意外暴露。
3. 确保在集中切换UV-C设备的开关处关闭电源。
4. 锁定并标记出处于关闭状态的可锁定开关。这是为了维护期间的安全，防止意外开启。
5. 从底部拆下4个盖螺母，拆下白色底板。
6. 把4盏灯从支架上拉出来。
7. 用柔软的无绒纤维布清洁灯具。

- 用柔软的无绒纤维布清洁反光镜。布料可以用纯酒精润湿。
- 将灯放回灯座。如果更换灯，将新灯放置在位置上。灯含有汞。更换的旧灯具应妥善处置！
- 重新定位白板，并将盖好的螺母放回位置。拧紧盖上的螺母。
- 离开 UV-C 光束的区域，并停留在可见标记保护所定义的自由可访问的区域。
- 从中央开关位置的开关中移除锁定标记。
- 打开电源。
- 重复调试过程，确保灯具更换后辐照度水平仍然可以接受。

如灯具破损，请按照以下指示：

清理前：

- 让人和宠物离开房间，避免在外出途中出现破损区域。
- 打开窗户或门到室外，离开房间5-10分钟。
- 关闭所有在运行的中央强制空气加热/空调(HVAC)系统。
- 将破损的光源及所有残留物，清理集中在一起。
- 硬纸或纸板
- 粘贴胶带（如封箱带）
- 湿纸巾或一次性湿巾（用于硬表面）
- 带金属盖的玻璃罐（如密封罐）或密封塑料袋

对于硬材质地面（如水泥地或大理石地面）的清理步骤

- 小心地将用玻璃碎片和粉末扫在硬纸或纸板上，并将碎片和纸或纸板放入装有金属盖的玻璃罐中。如果没有玻璃罐，请使用密封塑料袋。（注：由于塑料袋不能防止汞蒸汽的泄漏，所以在清洁后请勿将塑料袋滞留在家中。）
- 使用粘贴胶带（如封箱带），粘起任何剩余的玻璃碎片和粉末。将用过的胶带放入玻璃罐或塑料袋中。
- 用湿纸巾或一次性湿巾将区域擦拭干净。将用过的湿巾放入玻璃罐或塑料袋中。
- 不建议在清理过程中对硬材质地面进行吸尘处理，除非在采取上述所有清理步骤后，碎玻璃仍然存在。[注意：吸尘处理可能会造成含汞粉末或汞蒸汽的扩散，尽管目前对这方面信息的了解还很有限。]如果需要用吸尘处理以确保去除所有破碎的玻璃，请记住以下提示：
 - 确保窗户或门已打开，保持室内通风。
 - 如果吸尘装置有真空软管，请用真空软管对光源破损所涉及到的区域进行真空清洁处理。
 - 丢掉真空袋（或清除及清理），并将用完的真空袋/清理出的碎片或任何残留物密封在塑料袋中。
- 及时将所有玻璃碎片和残留物，包括吸尘袋，放在室外的垃圾桶或垃圾隔离区，直到将被处理掉。避免在室内留下任何破损光源碎片及相关残留物。
- 向当地政府询问你所在地区的此类废弃物的处理要求，因为有些地方要求将荧光灯泡（无论是否完好或已损坏的）带到当地的回收中心。如果你所在地区没有这样的要求，可以把它当成家庭垃圾处理。
- 在处理完含有灯破损光源碎片及相关残留物的罐子或塑料袋后，请记得用肥皂洗手。
- 对于发生过光源破损的房间，请继续保持通风，并将换气或空调系统关闭，视实际情况持续若干小时。

对于地毯或地垫的清理步骤

- 小心地将用玻璃碎片和粉末扫在硬纸或纸板上，并将碎片和纸或纸板放入装有金属盖的玻璃罐中。如果没有玻璃罐，请使用密封塑料袋。（注：由于塑料袋不能防止汞蒸汽的泄漏，所以在清洁后请勿将塑料袋滞留在家中。）
- 使用粘贴胶带（如封箱带），粘起任何剩余的玻璃碎片和粉末。将用过的胶带放入玻璃罐或塑料袋中。
- 不建议在清理过程中对硬材质地面进行吸尘处理，除非在采取上述所有清理步骤后，碎玻璃仍然存在。[注意：吸尘处理可能会造成含汞粉末或汞蒸汽的扩散，尽管目前对这方面信息的了解还很有限。]如果需要用吸尘处理以确保去除所有破碎的玻璃，请记住以下提示：
 - 确保窗户或门已打开，保持室内通风。
 - 如果吸尘装置有真空软管，请用真空软管对光源破损所涉及到的区域进行真空清洁处理。
 - 丢掉真空袋（或清除及清理），并将用完的真空袋/清理出的碎片或任何残留物密封在塑料袋中。
- 及时将所有玻璃碎片和残留物，包括吸尘袋，放在室外的垃圾桶或垃圾隔离区，直到将被处理掉。避免在室内留下任何破损光源碎片及相关残留物。
- 向当地政府询问你所在地区的此类废弃物的处理要求，因为有些地方要求将荧光灯泡（无论是否完好或已损坏的）带到当地的回收中心。如果你所在地区没有这样的要求，可以把它当成家庭垃圾处理。

6. 在处理完含有灯破损光源碎片及相关残留物的罐子或塑料袋后，请记得用肥皂洗手。
7. 对于发生过光源破损的房间，请继续保持通风，并将换气或空调系统关闭，视实际情况持续若干小时。

对于地毯或地垫的进一步清理：

1. 在吸尘处理过程及吸尘后保持室内通风。
2. 关闭所有在运行的中央强制空气加热/空调(HVAC)系统，打开窗户保持室内通风，重复对地毯或地垫的吸尘若干次，每次对这个区域进行吸尘后请更换吸尘袋。
3. 吸尘处理完成后，请继续保持通风，并将换气或空调系统关闭，视实际情况持续若干小时。

4 关于可预测到的不正确操作、故障和危险失效模式的警告。

故障类型	潜在影响	故障的潜在原因/原理	预防
消毒区域的辐照度太低	辐射量不足导致消毒率降低，这可能导致空气中的细菌仍处于活跃状态	应用环境温度	温度监测，确保温度在灯具规格要求的描述范围内
	辐射量不足导致消毒率降低，这可能导致空气中的细菌仍处于活跃状态	UV-C 照射区域被遮挡	确保 UV-C 照射区域没有被其他物体遮挡
	辐射量不足导致消毒率降低，这可能导致空气中的细菌仍处于活跃状态	UV-C 光源积灰	确保 UV-C 光源干净，无灰尘
没有辐照度导致无消毒作用	灯具不亮	灯具开关没有启动	根据本操作指南要求，以安全的方式启动开关
	灯具整流器不工作	灯具安装时输入线没有连接	根据本操作指南要求进行灯具的接线
	光源不亮	整流器寿命到期或整理期失效	须由授权的经销商更换整流器
人停留或暴露于高辐照强度下的时间超过 8 小时	意外暴露于 UV-C 环境下会导致皮肤有类似晒伤的反应或对视网膜的严重伤害	墙面的反射率过高	安装后不允许改变房间布局。
人停留或暴露于高辐照强度下的时间超过 8 小时	意外暴露于 UV-C 环境下会导致皮肤有类似晒伤的反应或对视网膜的严重伤害	墙面的反射率过高	空间内有可移动的墙面，由于移动导致的房间空间布局变小。
意外暴露于灯具的最大辐照角度内	意外暴露于 UV-C 环境下会导致皮肤有类似晒伤的反应或对视网膜的严重伤害	未遵循可进入区域高度限制的警示	查阅培训资料和本操作指南。使用并遵循可进入区域高度限制的警示
意外暴露于灯具的最大辐照角度内	意外暴露于 UV-C 环境下会导致皮肤有类似晒伤的反应或对视网膜的严重伤害	现场没有安放可进入区域高度限制的警示	查阅培训资料和本操作指南。使用并遵循可进入区域高度限制的警示
在替换光源过程中光源破损	光源中泄漏的汞，可能会污染周围的物体表面和房间	替换光源时，光源意外掉落	替换光源时请当心，并按照本操作指南要求。在发生光源破损的情况下，请按照按照本操作指南要求来清洁汞的污染。
UV-C 对物品和周围环境的损害	UV-C 会导致材料降解，油漆褪色	在灯具正常运行中，贵重物品和易受 UV-C 损害的物品没有得到有效保护	确保所有贵重品/物件/标志被移除，隐藏或保护，不受到 UV-C 的直接照射

(CS)安全预防措施



- 依据IEC-62471，本灯具的UV-C风险评级为3级。
- 警告：本灯具照射出的是UV-C光线。请勿将眼睛和皮肤暴露于未被屏蔽的灯具。请遵循本安装说明和操作指南。
- 警告：我们的UV-C产品不期望也不应该用于由于使用该产品或因产品失效可能导致死亡、人身伤害和/或环境损害的应用或活动中。
- 由于UV-C是人眼不可见的，所以UV-C产品的安装必须有遵从本说明要求，具备充足的保障措施，以确保UV-C产品可以安全操作。



- UV-C产品作为应用场所里的一种设备，除了满足本产品安装说明和操作指南中所有的安全保障措施外，还应符合该应用场所对此类产品的相关安装及操作要求。
- 警告：不要在没有阅读本说明（安装说明和操作指南）的情况下使用本产品，确保控制解决方案符合相关的安全条款并已通过安全培训。
- 警告：长期暴露在UV-C辐射下的材料会退化或变色。



- 光源内含汞。万一灯管意外破碎，应先通风30分钟，处理时应戴上手套取出碎片，装进密封塑料袋内，带到当地的废物处理点进行安全处理。不要使用吸尘器。请严格遵循本操作指南。
- 灯具应由有资格的电工安装，接线要符合IEE电气标准或当地的特殊要求。
- 整流器绝缘，符合IEC61347-1。
- 在安装过程中或维护灯具时，请使用防静电手套，以避免灯具上的留下印记。
- 清除污垢和斑点，请使用以下方法：
- 灰尘：只使用无绒纤维布。
- 指纹：用具有抗静电性能的合成类材料的清洁剂。